

MACHINE MODEL

H 800 NC F3000

Automatic double column bandsaw for straight cuts

Short description

H 800 NC F3000 is an automatic double column bandsaw suitable for straight cuts of carpentry works, pipes and solid materials, an affordable working tool for every professional user. The machine uses an innovative interface with 10" , touch screen display, guarantees for the highest cutting performances thanks to its rigid structure and 5° canted blade



Cutting capacity at 0°	Round: 680mm - Square: 640mm - Rectangular: 820x610mm
Cutting capacity with bundle cutting	Max. 800x330mm - Min. 50x50mm
Cutting capacity at 0° for solid (C45)	350mm
Blade size	7950x41x1.3mm
Blade speed	15/100 m/min
Blade motor power	5.5KW
Feeder length	1500mm
Feeder motor power	1.5KW
Minimal scrap-end	350mm
Minimum cutting length	30m
Working area height	815mm
Size	4350x3600x2700mm
Weight	4455kg

Features



10" touch screen display

H 800 NC has an easy and intuitive interface dedicate to optimize the user-experience: thanks the CNC system and 10" touch screen display the user can manage all the machine operative function, set up 99 cutting program and multiple cutting length on the same bar, set the number of feeder stroke, the number of pieces and blade speed. It's also possibile to do an autodiagnostic to detect errors.

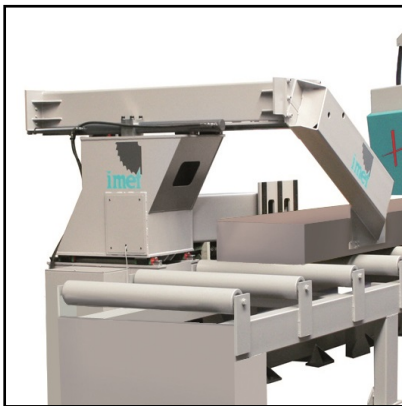

Feeder

Feeder length is 3000mm with automatic stroke repetition, movement on linear ball guides. Minimum scrap end on the single cut is 150mm and 325mm with bundle cutting. H 800 NC has a high positioning precision and stroke repetition thanks to the innovative system geared motor driven by inverted and controlled by a linear or encoder and mechanical clamping.

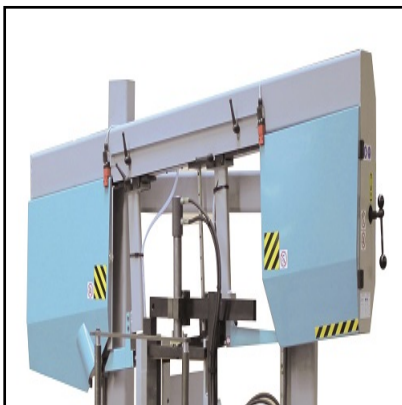

Rigid sawframe

H 800 NC has a big size, electrowelded bow with rigid structure and big thickness. The massive structure helps reduce any vibration, binding or slowing during the cutting process, saving sawblade life and durability. High Cutting performances even on the biggest sections and full materials are provided by the 5° canted blade with 2000kg/cm2 blade tension.

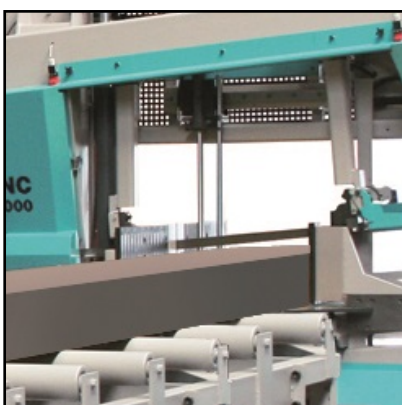

Material detection device

H 800 and H 1200 are equipped with an automatic detection material system which also detect the first cut point thanks to a magnetic strip with encoder for material reading: the operator must set the material size on the panel control, the machine starts the automatic fast lowering of the sawframe up to the set value. This process allows to have a faster and easier approach to the material, helping saving time.



Blade speed

H 800 NC F3000 is equipped with ESC electronic inverter for variable speed so that the machine is suitable to cut multiple materials (even bigger section and solids)



Vice

The machine has an hydraulic horizontal vice sliding on the working place. The vice uses a system with opening jaws on both sides to ease the loading of non-rectilinear bars.



Washing gun

Premium Line automatic bandsaws and semiautomatic and automatic Maxi Line bandsaws are standardly equipped with a washing gun dedicated to keep clean the working area and remove any residuals and remainings, allowing to keep the highest efficiency of the machine.



Industry 4.0 - SAWFACTORY (Optional)

OPTIONAL

IMET automatic machines can be connected to the company network and be used remotely thanks to SAWFACTORY and modem. SAWFACTORY is a dedicated software which allows to manage the cutting process from the office desk by setting cutting programs and monitoring the workflow thanks to the dedicated web app. The software also allows to also receive assistance by our technicians remotely. Discover SAWFACTORY: <https://bit.ly/2RuxHuX>



Minimal lubrication system (Optional)

OPTIONAL

It is possible to require , for all Imet machines, the minimal lubrication system , it avoids the dispersion of refrigerant liquid typical in the use of emulsifiable oil, the life of the blade is not in any way affected Lubrification system tank has a 3 liter capacity.



Laser ray (Optional)

OPTIONAL

The laser ray is dedicated to optimize the user workflow by pointing the cutting line on the material with a laser ray projection.

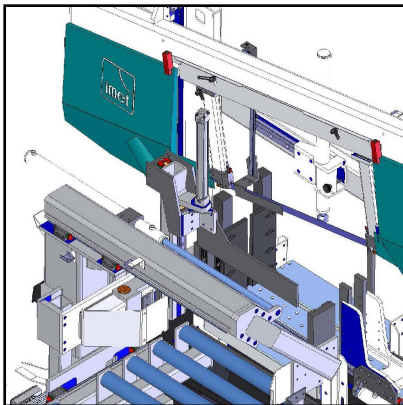

Bundle cutting device(Optional)

OPTIONAL

Hydraulic device for bundle cutting (Max: 800x330mm - Min: 50x50mm)



Metal protection barriers (Optional)

OPTIONAL

According to CE law, it's also available the protection safety system made by metallic barriers that covers the machine on the 4 side with CNC managed access doors to regulate and control the operator access to the . working area.



Pair of safety photocells (Optional) OPTIONAL

It's possible, if the user doesn't want a full metallic barriers protection system, to install a pair of photocells instead of one of the metallic side.



Loading/unloading roller table (Optional) OPTIONAL

Loading and unloading roller table with free rolls: it includes 2 vertical containment rolls on one side. Length: 2m.



Motorized roller table (Optional) OPTIONAL

Motorized roller table with preset for motorization with chain transmission and pinions.



Motorization system (Optional) OPTIONAL

Motorization system for motorized roller table. Recommended every 6m motorized roller table. Max speed 10m/min.